

## FANUC Robot ARC Mate 100iD FANUC Robot ARC Mate 120iD

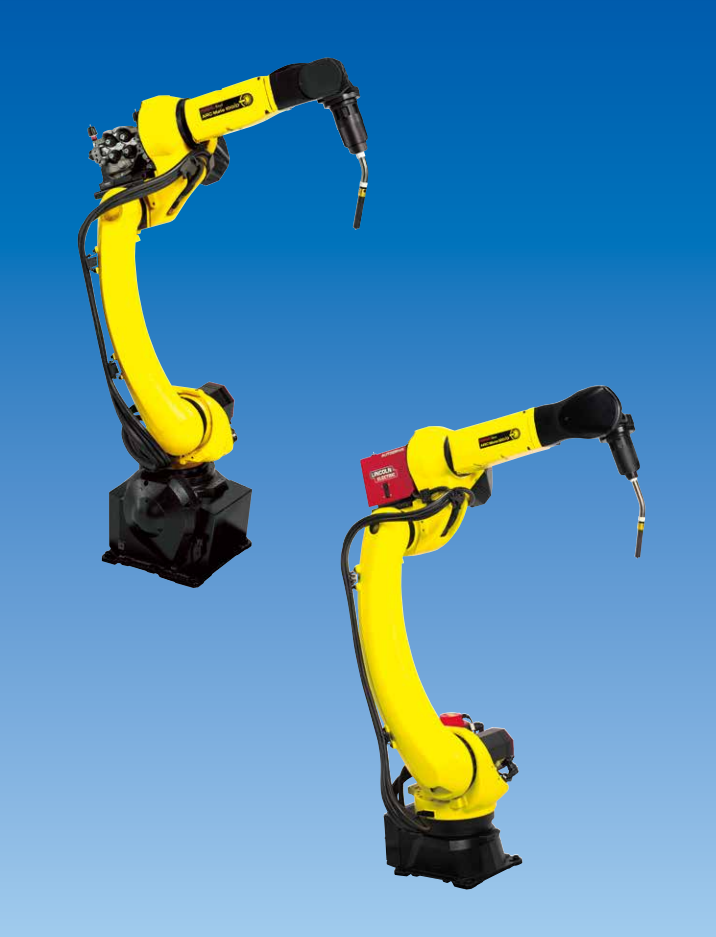

### FEATURES

FANUC Robot ARC Mate 100iD / 120iD is the cables integrated arc welding robot with an enhanced dress-out ability.

- The robot is available to meet a variety of operating spaces.
- The unique gear drive mechanism realizes the slim arm of the torch cable integrated robot.
- Welding cable utilities backside the wire feeder can be integrated in the enlarged J1 hollow tube. It makes system setup easy.
- Not only the torch cable but also the sensor cable can be integrated in the J3 arm due to the enlarged J4 and J6 hollow tubes. The wire feeder can be compactly mounted backside of the J3 arm.
- Higher rigidity of the arm provides high speed and high accuracy of the robot motion. It can enhance the productivity of the system.
- Off-line teaching by ROBOGUIDE (Option) reduces touch-up cost.
- Various intelligent functions with *i*RVision (integrated vision) and coordinated motion with the positioner are available.

### Application Examples



Automotive part welding



Stainless part welding

## Operating space

### ARC Mate 100iD, /10L, /8L

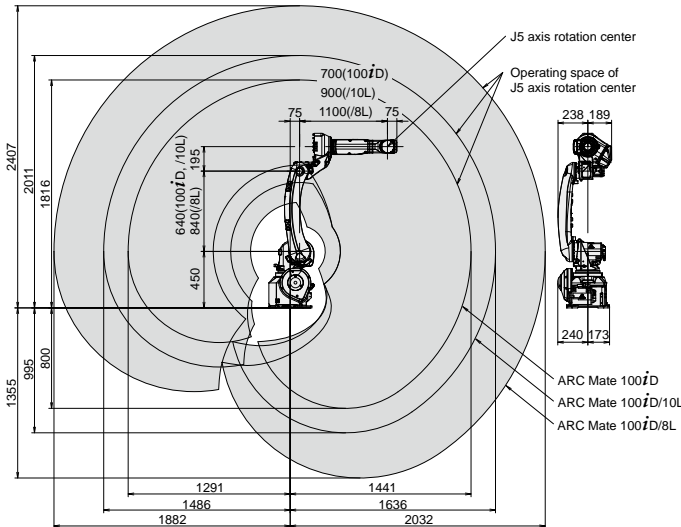
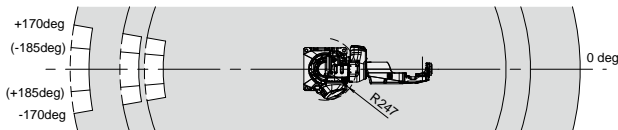

### ARC Mate 120iD, /12L

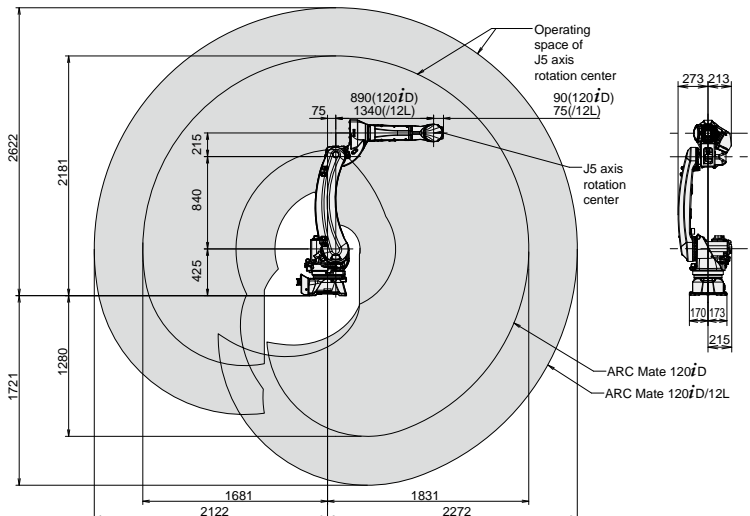
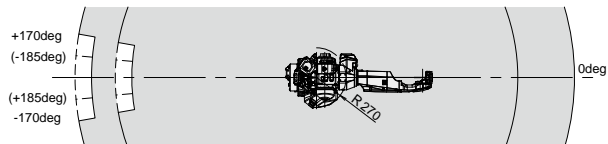

## Specifications

Model		ARC Mate 100iD	ARC Mate 100iD/10L	ARC Mate 100iD/8L	ARC Mate 120iD	ARC Mate 120iD/12L
Type		6 axes(J1,J2,J3,J4,J5,J6)				
Reach		1441 mm	1636 mm	2032 mm	1831 mm	2272 mm
Installation		Floor, Upside-down, Angle mount *Floor, Upside-down for 4 brake type		Floor, Upside-down, Angle mount		
Motion range (Maximum speed) Note 1, 2)	J1 axis rotation	340° / 370°(Option)(260°/s) 5.93 rad / 6.46 rad(Option)(4.54 rad/s)		340° / 370°(Option)(210°/s) 5.93 rad / 6.46 rad(Option)(3.67 rad/s)		
	J2 axis rotation	235° (240°/s) 4.10 rad (4.19 rad/s)		235° (210°/s) 4.10 rad (3.67 rad/s)	260° (210°/s) 4.54 rad (3.67 rad/s)	
	J3 axis rotation	455° (260°/s) 7.94 rad (4.54 rad/s)		455° (220°/s) 7.94 rad (3.84 rad/s)	458° (265°/s) 8.00 rad (4.63 rad/s)	
	J4 axis wrist rotation	380° (430°/s) 6.63 rad (7.50 rad/s)		400° (420°/s) 6.98 rad (7.33 rad/s)		
	J5 axis wrist swing	360° (450°/s) 6.28 rad (7.85 rad/s)		360° (420°/s) 6.28 rad (7.33 rad/s)		360° (450°/s) 6.28 rad (7.85 rad/s)
	J6 axis wrist rotation	900° (720°/s) 15.71 rad (12.57 rad/s)				
Max load capacity at wrist		12 kg	10 kg	8 kg	25 kg	12 kg
Allowable load moment at wrist	J4 axis	26.0 N·m	22.0 N·m	16.1 N·m	52.0 N·m	22.0 N·m
	J5 axis	26.0 N·m	22.0 N·m	16.1 N·m	52.0 N·m	22.0 N·m
	J6 axis	11.0 N·m	9.8 N·m	5.9 N·m	32.0 N·m	9.8 N·m
Allowable load inertia at wrist	J4 axis	0.90 kg·m <sup>2</sup>	0.65 kg·m <sup>2</sup>	0.63 kg·m <sup>2</sup>	2.40 kg·m <sup>2</sup>	0.65 kg·m <sup>2</sup>
	J5 axis	0.90 kg·m <sup>2</sup>	0.65 kg·m <sup>2</sup>	0.63 kg·m <sup>2</sup>	2.40 kg·m <sup>2</sup>	0.65 kg·m <sup>2</sup>
	J6 axis	0.30 kg·m <sup>2</sup>	0.17 kg·m <sup>2</sup>	0.061 kg·m <sup>2</sup>	1.20 kg·m <sup>2</sup>	0.17 kg·m <sup>2</sup>
Repeatability Note 3)		± 0.02 mm		± 0.03 mm		± 0.02 mm
Mass Note 4)		145 kg	150 kg	180 kg	250 kg	
Installation environment		Ambient temperature : 0 to 45°C Ambient humidity : Normally 75%RH or less (No dew nor frost allowed), Short term 95%RH or less (within one month) Vibration acceleration : 4.9m/s <sup>2</sup> (0.5G) or less				

Note 1) In case of angle mounting, J1 and J2 axis motion range are restricted.

Note 2) During short distance motions, the axis speed may not reach the maximum value stated.

Note 3) Compliant with ISO9283.

Note 4) Without controller.

# FANUC CORPORATION

Headquarters Oshino-mura, Yamanashi 401-0597, Japan  
Phone: 81-555-84-5555 Fax: 81-555-84-5512 <https://www.fanuc.co.jp>

●Overseas Affiliated Companies  
FANUC America Corporation  
FANUC Europe Corporation, S.A.  
SHANGHAI-FANUC Robotics CO., LTD.  
KOREA FANUC CORPORATION  
TAIWAN FANUC CORPORATION  
FANUC INDIA PRIVATE LIMITED  
FANUC SINGAPORE PTE. LTD.  
FANUC THAI LIMITED  
FANUC MECHATRONICS (MALAYSIA) SDN. BHD.  
  
PT. FANUC INDONESIA  
FANUC OCEANIA PTY. LIMITED  
FANUC SOUTH AFRICA (PROPRIETARY) LIMITED

3900 West Hamlin Road, Rochester Hills, MI 48309-3253, U.S.A.  
7, rue Benedikt Zender, L-6468 Echternach, Grand-Duché de Luxembourg  
No. 1500 Fulian Road, Baoshan Area, Shanghai, China  
101, Wanam-ro(st), Seongsan-gu, Changwon-si, Gyeongsangnam-do, 642-290 Republic of Korea  
No.10, 16th Road, Taichung Industrial Park, Taichung, Taiwan  
41-A, Electronics City, Bangalore, 560 100, India  
No.1 Teban Gardens Crescent, Singapore 608919, Singapore  
1301 Pattanakorn Road, Kwaeng Suanluang, Khet Suanluang, Bangkok 10250 Thailand  
No.32, Jalan Pengacara U1/48, Temasya Industrial Park, Section U1, Glenmarie,  
40150 Shah Alam, Selangor Darul Ehsan, Malaysia  
JL. Boulevard Bukit Gading Raya Blok R, Jakarta 14240 Indonesia  
10 Healey Circuit, Huntingwood, NSW 2148, Australia  
17 Loper Ave. Aeroport Industrial Ests. Spartan Ext.2 P.O.Box 219, Isando 1600, Republic of South Africa

Phone: 1-248-377-7000 Fax: 1-855-774-7051  
Phone: 352-727777-1 Fax: 352-727777-403  
Phone: 86-21-5032-7700 Fax: 86-21-5032-7711  
Phone: 82-55-278-1200 Fax: 82-55-284-9826  
Phone: 886-4-2359-0522 Fax: 886-4-2359-0771  
Phone: 91-80-2852-0057 Fax: 91-80-2852-0051  
Phone: 65-6567-8566 Fax: 65-6566-5937  
Phone: 66-2-714-6111 Fax: 66-2-714-6120  
  
Phone: 60-3-7628-0110 Fax: 60-3-7628-0220  
Phone: 62-21-4584-7285 Fax: 62-21-4584-7288  
Phone: 61-2-8822-4600 Fax: 61-2-8822-4666  
Phone: 27-11-392-3610 Fax: 27-11-392-3615

- All specifications are subject to change without notice.
- No part of this catalog may be reproduced in any form.
- The products in this catalog are controlled based on Japan's "Foreign Exchange and Foreign Trade Law". The export from Japan may be subject to an export license by the government of Japan. Further, re-export to another country may be subject to the license of the government of the country from where the product is re-exported. Furthermore, the product may also be controlled by re-export regulations of the United States government. Should you wish to export or re-export these products, please contact FANUC for advice.

© FANUC CORPORATION, 2016

ARCMate100iD(E)-06, 2019.12, Printed in Japan